

MTL SD Modular range

Safeguards electronic equipment and systems against surges on signal and I/O cabling

- Slim, modular, space saving design
- Multi stage hybrid circuit
- 20kA maximum surge current
- Voltage ratings to suit process I/O applications
- Intrinsically safe
- ATEX and IECEx certified
- 10 year warranty



The MTL SD modular range takes the established SD range of high performance surge protectors for I/O and introduces a replaceable element. Maintaining the unrivalled packing density and field proven hybrid circuit design the modular range makes maintenance easy, enabling the replacement of surge protection modules without disconnecting the loop.

The multi-stage high performance hybrid circuit provides protection for I/O in the most demanding applications in the most hostile areas of the world where the traditional SD has been established as a market leader. Each plugin module provides full hybrid line-line and line-ground protection.

The base design can double up as a basic feed-through terminal to which the surge protection is added at a later stage. The SDFTMXX module should be selected for permanent feed through applications.

The MTL SD modular range of products is backwards compatible with existing installed SD's. The footprint will enable the user to replace already installed SD's with the new modular design.

The addition of the MTL SD modular will enhance any process control system by ensuring maximum availability and ultimate reliability. These surge protectors will ensure the operation and up-time of the most critical systems failure.

The MTL SD**MXL diagnostic LED option, provides visual indication of degradation of voltage limiting components, reducing the effectiveness of the surge protection module, generally after repeated surge events. The LED variant is optimised for AI/DI applications. The LED option will assist maintenance personnel in rapidly identifying the failed module requiring replacement.

The MTL Data surge tester allows the continued effectiveness of the surge protection function to be tested by removing the surge protection module from the base and plugging it into the tester.

Designed from the outset using our experience of safety management the MTL SD modular will be suitable for use in safety systems most commonly used today. Additionally our leadership in the intrinsic safety market guarantees attention to detail where safety is paramount.

The hot swappable design of the SD**M module with the SDBE-BC* feed-through base option allows replacement of the module without interruption of the process signal. Careful design, to give a "make before break" contact configuration, is further enhanced by the earth connection being the first to "make" and the last to "break" giving added safety for taking any residual voltages down to earth.

The cable screen can either be connected directly to Earth with the SDBE-B*N option or alternatively the screen is isolated from ground with a Gas Discharge Tube (GDT) providing a path to ground during a surge event with the SDBE-B*G version.

The MTL SD**MFX fuse option provides both fused protection against fault currents and a convenient method of isolating field circuitry from protected circuitry without needing additional disconnect terminals. The standard fuse (which is replaceable) is rated 250mA. As an example, this feature is of particular value in applications in which an SPD is used with a bulk power supply feeding multiple loops. The individual module fuse prevents a fault or follow on current on one loop disrupting the power supply to the others. Also, loops can be removed from the circuit for maintenance reasons or added without needing additional disconnect terminals. Where only the disconnect feature is required, the SD**MDX solid link disconnect option can be selected.

One simple operation clamps the base securely to the DIN rail and automatically provides the high integrity earth (ground) connection.

MTL SD Modular range

April 2017

SPECIFICATION

All figures typical at 25°C (77°F) unless otherwise stated

Protection

- Full hybrid line to line
- Each line to screen/ground

Max discharge surge current (I_{max}) (8/20 μ s)
20kA (8/20 μ s)

Nominal discharge surge current (i_{sn})
5kA (8/20 μ s)

Lightning impulse current (I_{imp}) (10/350 μ s)
1.2kA

Response time
<1ns

Ambient temperature
-40°C to +80°C (-40°F to 176°F) working
For IS applications see approvals table
-40°C to +80°C (-40°F to 176°F) storage

Humidity
5 to 95% RH (non-condensing)

Category tested
A2, B2, C1, C2, C3, D1

Overstressed fault mode (i_{in} =3kA)
17kA

Impulse durability (8/20 μ s)
5kA

Terminals
2.5mm² (12 AWG)

Mounting
T-section DIN-rail 35 x 7.5 or 35 x 15mm rail
(1.38" x 0.3" x 0.6")

Weight
70g approximately (2.5oz)

Case flammability
UL94 V-2

AC durability
1A_{rms} 5T

Service conditions
80kPa - 160kPa, 5% - 95% RH

EMC compliance
BS EN 61326-1:2013

IEC compliance
IEC 61643-21:2001

ANSI/IEEE testing
C62.41-1-2002, C62.41-2-2002, C62.45-2002

DIMENSIONS

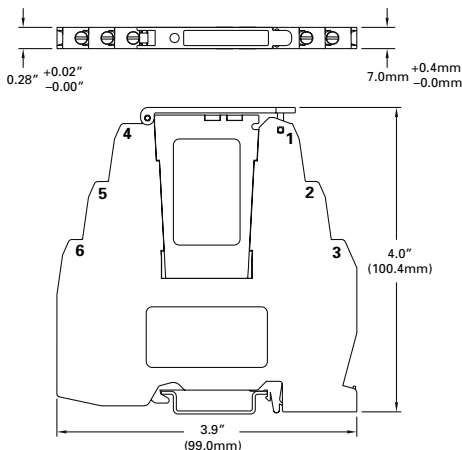

Model	Nominal voltage+ (U _n) (Vdc) (Vac)	Nominal current (I _n) * (mA)	Series resistance (Ω /line)	Max. leakage current (μ A)	Rated voltage (MCOV) (U _r)	Voltage protection level (U _p) @1kV/ μ s (V)	Residual voltage @I _{sn} (V)	Bandwidth (frequency) (f _G)	Special feature	
SD07M	7	5	700	< 1	500	7.7	<12	25	220kHz	Low resistance
SD16M	16	11	700	< 1	5	17	<25	35	220kHz	Low resistance
SD32M	32	22	700	< 1	5	36	<45	60	220kHz	Low resistance
SD55M	55	38	700	< 1	5	62	<90	90	220kHz	Low resistance

Note: all figures are typical at +25°C unless otherwise stated.
* If F version is selected, current is limited to 250mA.

Definitions of terminology used in table.

- Working voltage (Un)**
Maximum voltage between lines or lines/ground for the specified leakage current
- Maximum leakage current (Ic)**
Maximum current drawn by the SPD at the working voltage
- Maximum continuous operating voltage (Uc)**
Maximum voltage that can be applied to the protected terminals without damage
- Voltage protection level (Up)**
Peak output voltage after injection of test impulse from 1kV/ μ s generator (often known as 'let-through' voltage)
- Bandwidth**
Frequency range up to which ac signals can be transmitted without undue attenuation; 3dB into 50 Ω

SIL compatibility

The SD**M** module can be used in SIL 3 loops based on analysis conducted under IEC61508 type A "non complex" hardware. Dependent upon the defined system/loop test interval and the hardware fault tolerance the module will demonstrate compliance with SIL 3 systems.

APPROVALS

Country (Authority)	Standard	Certificate/ File No.	Approved for	Parameters
Europe (Baseefa)	EN 60079-0: 2012 + A11:2013 EN 60079-11:2012	Baseefa 02ATEX0211X	II 1 G Ex ia IIC T4 Ga	U _r = 20V, I _n = 260mA; or U _r = 26V, I _n = 175mA; or U _r = 28V, I _n = 140mA; or U _r = 60V, I _n = 65mA; or U _r = 75V, I _n = 40mA C _i = 0 L _i = 0.22mH P _i = see below*
International (IECEX)	IEC 60079-0:2011 IEC 60079-11:2011	IECEX BAS 12.0003X	Ex ia IIC T4 Ga	U _r = 20V, I _n = 260mA; or U _r = 26V, I _n = 175mA; or U _r = 28V, I _n = 140mA; or U _r = 60V, I _n = 65mA; or U _r = 75V, I _n = 40mA C _i = 0 L _i = 0.22mH P _i = see below*
USA (UL)	UL 497B Listed	E220693	Isolated loop communications circuit	-

* P_i = 1W (-30°C ≤ Ta ≤ 75°C); P_i = 1.2W (-30°C ≤ Ta ≤ 60°C); P_i = 1.3W (-30°C ≤ Ta ≤ 40°C)

ORDERING INFORMATION

Order insert and base together - see below - or individually

Part number codes - MODULE INSERT

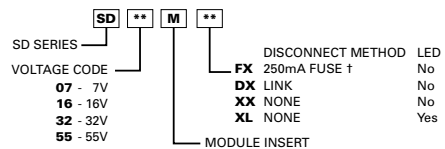

† Fuse option is not ATEX or IECEx certified

FEED THROUGH MODULE

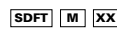

BASE MODULE

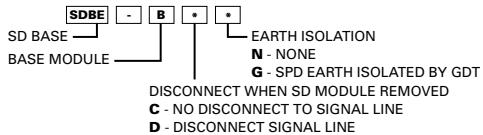

MTL DATA SURGE TESTER

MLDT28500

To order a module with base, specify, for example: SD 16 M D X - B D G to obtain a 16V insert with disconnect link in a base with signal disconnect on removal of insert and GDT isolation.