



# XMO2pro

## Oxygen Analyzer

Thanks to the perfectly matched interaction between the paramagnetic oxygen property and temperature, the Safety Integrity Level (SIL) certified XMO2pro is contamination resistant, requires minimal maintenance and needs no consumables. This makes it the ultimate choice for highly accurate oxygen measurements for widespread use in harsh environment industrial and oil & gas applications.

## Advanced Oxygen Analyzer

Designed for stability and longevity in hazardous area locations, the XMO2pro provides high accuracy percent-level measurements and brings the user:

- Innovative sensor design for durable and highly accurate measurements
- Intuitive operating interface allows for easy adoption and use
- Data transfer over the MODBUS digital communication port
- Minimal maintenance and high level of reliability with SIL 2 by design
- Compact design for cost-effective integration into the process

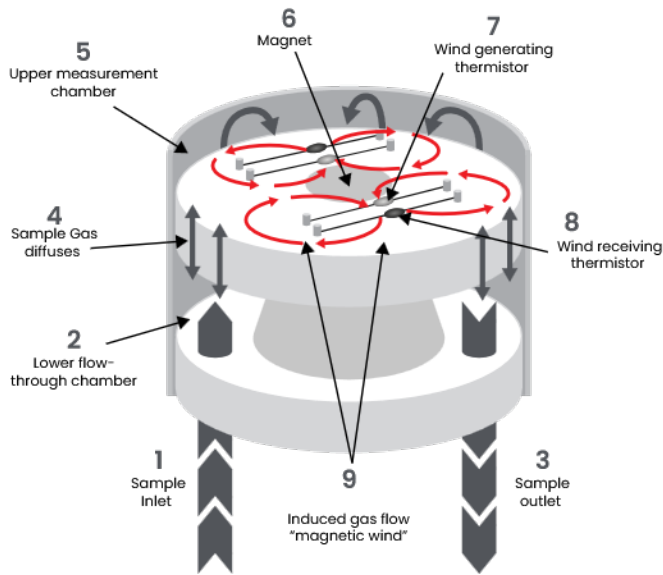

Flow diagram of the XMO2pro measuring cell

Sample gas continually flows through the lower flow-through chamber (1)(2)(3). This chamber acts as a pass-through and protects the sensor from contamination. A portion of the sample gas diffuses (4) into the upper chamber (5). The oxygen molecules are drawn into the center by the magnet (6) and leave across the heated matched thermistor pairs (7)(8) creating a "magnetic wind" (9). These thermistor pairs form part of a Wheatstone bridge, which generates a signal proportional to the oxygen concentration in the sample gas.

## Top performance and ease of use

The compact, weatherproof, explosion-proof and flameproof XMO2pro is specifically designed to be field installed at the process measurement point, thus minimizing sample conditioning requirements while ensuring the best sample and the fastest possible response. The XMO2pro requires no consumables, has no moving parts, is insensitive to vibration and therefore has excellent long-term reliability.

## Benefits

- Accurate measurements from 0.01% to 100% O<sub>2</sub> in gases
- Compact design for cost-effective integration into the process
- Explosion-proof and flameproof certified with weatherproof protection allows sensor to be remotely mounted at the measurement point
- Unique, temperature-controlled dual-chamber cell design that is resistant to contamination and flow fluctuations
- Compact, rugged sensor design with no moving parts provides long term reliability and trouble-free operation
- High-contrast display, large magnetic buttons for easy control under different environmental conditions
- Intuitive user interface enables easy and flexible use
- The MODBUS communication port provides extended information with configurable options
- Minimal on-site/user-controllable maintenance

## Applications

- Inerting/blanketing liquid storage tanks
- Reactor feed gases
- Centrifuge gases
- Catalyst regeneration
- Solvent recovery
- Landfill/Biogas processing
- Sewage wastewater digester gas
- Oxygen purity
- Reaction optimization

## Choice of enclosures and ranges

The XMO2pro requires 24 VDC power and provides a 4 to 20 mA output signal with fully programmable zero and span settings. The output is proportional to oxygen concentration and internally compensated for background gas and/or atmospheric pressure variations. The additional 4-20 mA output can be configured by the operator to provide an alternative concentration range using the calibration of the first 4-20mA output. The weatherproof and explosion-proof options are available in a wide variety of measurement ranges.

## Sample System

Sample systems deliver a clean, representative sample to the XMO2pro at optimal temperatures, pressures and flow rates. Panametrics offers sample systems for a wide variety of applications.

For assistance in designing your own sample system, please consult our application engineering team.

## Automatic background gas compensation

An onboard microprocessor gives the XMO2pro the computing power to provide advanced online signal conditioning and MODBUS digital communications. Integrated signal-processing algorithms provide improved linearity and accuracy, and automatic compensation for background gas variations and/or atmospheric pressure effects. A fast response software routine provides typical response time of less than 15 seconds.



# Technical Specifications



- 1 Configuration and certification information
- 2 Mounting holes
- 3 Cable entries
- 4 Removable top cover
- 5 Removable front cover
- 6 Multi-parameter display
- 7 Magnetic keypad
- 8 Flame arrestors (gas inlet/outlet) and breather

## Performance

<b>Accuracy</b>	<ul style="list-style-type: none"> <li>• ±1% of span</li> <li>• ±2% of span for 0 to 1% range</li> </ul>
<b>Linearity</b>	±0.5% of span
<b>Repeatability</b>	±0.2% of span
<b>Zero Stability</b>	±1% of span per month (±2% for 0 to 1% range)
<b>Span Stability</b>	±0.4% of span per month (±0.8% for 0 to 1% range)
<b>Measurement Ranges</b>	<ul style="list-style-type: none"> <li>• 0% to 1%</li> <li>• 0% to 2%</li> <li>• 0% to 5%</li> <li>• 0% to 10%</li> <li>• 0% to 21%</li> <li>• 0% to 25%</li> <li>• 0% to 50%*</li> <li>• 0% to 100%*</li> <li>• 80% to 100%*</li> <li>• 90% to 100%*</li> </ul>
<b>Pressure effect</b>	<ul style="list-style-type: none"> <li>• ±0.2% of span per mm Hg (without atmospheric pressure compensation)</li> <li>• Option available for atmospheric pressure compensation</li> </ul>
<b>Required sample flow rate</b>	<ul style="list-style-type: none"> <li>• Nominal: 500 cc/min (1.0 SCFH)</li> <li>• Range: 50–1000 cc/min (0.1–2.0 SCFH)</li> <li>• Max: 1250 cc/min (2.7 SCFH)**</li> </ul>
<b>Sample flow rate effect</b>	Less than 1% of span for flow range of 50 to 1000 cc/min (0.1 to 2.0 SCFH)
<b>Response time, 90% step change</b>	Standard: 70 seconds EN50104: 45 seconds Fast-Response Option: 15 seconds

\*Pressure compensation required

\*\*Maximum permitted per Annex G of IEC60079-1

## Functional and Physical

<b>Warm-up time</b>	30 minutes
<b>Functional Safety</b>	IEC61508 SIL 2 (optional)
<b>Analog output</b>	Two 4 to 20 mA isolated, 550 Ω maximum load, field-programmable
<b>Digital output</b>	Modbus RS232/RS485 (Fixed to RS232 on the no display model)
<b>Power</b>	24 VDC ±4 VDC, 2 A
<b>Ambient temperature range (Sample conditions)</b>	<ul style="list-style-type: none"> <li>• -20 to 40°C (-4 to 104°F), standard operating temperature</li> <li>• -5 to 55°C (23 to 131°F), optional operating temperature</li> </ul>
<b>Operating pressure</b>	<ul style="list-style-type: none"> <li>• Close to atmospheric</li> <li>• Max 2 barg (29 psig)</li> </ul>
<b>Wetted sensor materials</b>	<ul style="list-style-type: none"> <li>• Standard: 316 stainless steel, glass and Viton® O-rings</li> <li>• Optional: Hastelloy® C276 and Chemraz® O-rings</li> <li>• Optional: 316 Stainless steel, glass and Chemraz® O-Rings</li> </ul>
<b>Dimensions</b>	<ul style="list-style-type: none"> <li>• Wp. (H x D x W): 228 x 178 x 142mm (9 x 7 x 6in)</li> <li>• Ex-proof (H x D x W): 252 x 178 x 142mm (10 x 7 x 6in)</li> </ul>
<b>Weight</b>	<ul style="list-style-type: none"> <li>• Aluminum version: 4.5kg / 9.9 lb</li> <li>• Stainless Steel version: 11.0 kg / 24.2 lb</li> </ul>
<b>Environmental</b>	IP66, Type 4X
<b>IECEx compliance</b>	<ul style="list-style-type: none"> <li>• Ex db IIC T6 Gb, Ex tb IIIC T78°C Db IP66</li> <li>• -20°C &lt; Tamb &lt; +55°C</li> </ul>
<b>European Union Compliance</b>	<ul style="list-style-type: none"> <li>• EMC Directive 2014/30/EU</li> <li>• ATEX 2014/34/EU: II 2 GD Ex db IIC T6 Gb, Ex tb IIIC T78°C Db IP66</li> <li>• -20°C &lt; Tamb &lt; +55°C</li> </ul>
<b>NEC/CEC</b>	<ul style="list-style-type: none"> <li>• CI I, II, III Div 1/Div 2. Groups ABCDEFG, T6</li> <li>• -20°C &lt; Tamb &lt; +55°C</li> </ul>

Aluminum Version

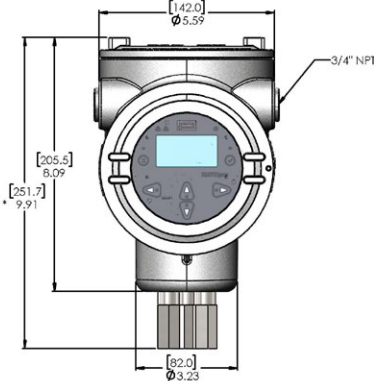
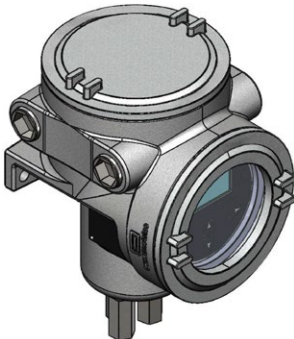

\*8.96 [227.6] WEATHERPROOF VERSION

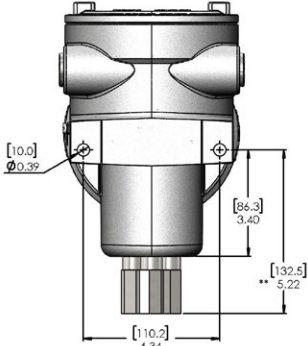

\*\*4.27 [108.5] WEATHERPROOF VERSION

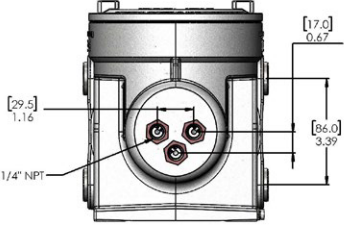
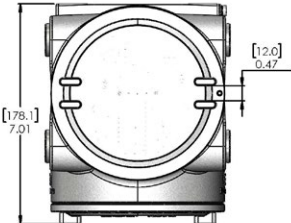

[mm]  
in

Stainless Steel Version

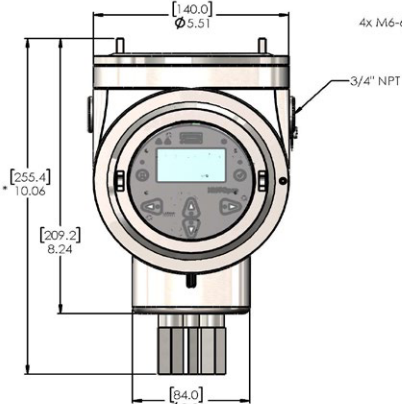
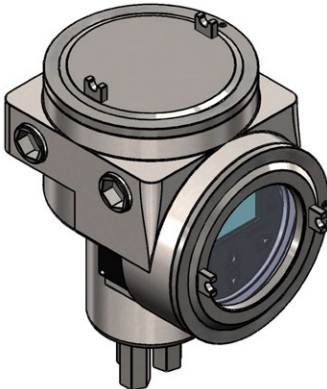

\*9.11 [231.4] WEATHERPROOF VERSION

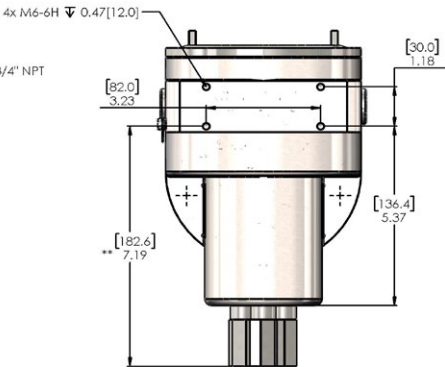

\*\*6.24 [158.5] WEATHERPROOF VERSION

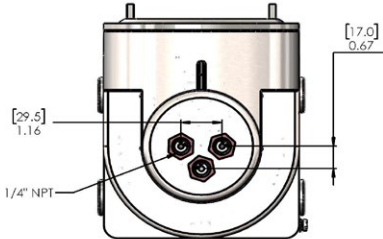
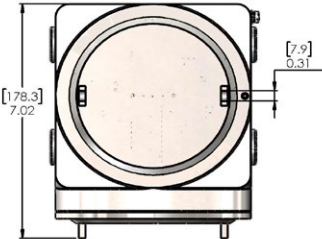

[mm]  
in

# Order and calibration information

Installation Site Requirements	Model	XMO2pro	XMO2pro, Thermoparamagnetic Oxygen AnalyzerEnclosure
		<b>Enclosure Package</b>	
		1	Aluminium enclosure, weatherproof, with display
		2	Aluminium enclosure, explosion proof, with display
		3	Stainless steel enclosure, weatherproof, with display
		4	Stainless steel enclosure, explosion proof, with display
		5	Aluminium enclosure, weatherproof, no display
		6	Aluminium enclosure, explosion proof, no display
		7	Stainless steel enclosure, weatherproof, no display
		8	Stainless steel enclosure, explosion proof, no display
9	Without enclosure		
	<b>Wetted Material</b>		
	1	316 Stainless Steel, Viton O-Rings	
	2	Hastelloy, Chemraz O-Rings	
	3	316 Stainless Steel, Chemraz O-Rings	
	<b>Certification</b>		
	1	Safe Area/General Purpose Area	
	2	USA/CAN Div 1, Zone 1/21	
	3	USA/CAN Div 2, Zone 2/22	
	4	ATEX/IECEX	
	<b>Cell Temperature Set Point</b>		
0	Standard Operating Temperature		
1	High Operating Temperature		
	<b>Response Time</b>		
	0	Standard Response	
	1	EN 50104 (45 seconds)	
	2	Fast Response	
	<b>Oxygen Output Range</b>		
	1	0 to 1%	
	2	0 to 2%	
	3	0 to 5%	
	4	0 to 10%	
	5	0 to 21%	
6	0 to 25%		
7	0 to 50%		
8	0 to 100%		
9	80 to 100%		
10	90 to 100%		
S	OTHER		
	<b>Compensation Signal</b>		
	0	Background Gas Compensation, N <sub>2</sub> /CO <sub>2</sub>	
	1	Atmospheric Pressure Compensation, N <sub>2</sub>	
	2	Background Gas Compensation, Special Gas	
	3	Atmospheric Pressure Compensation, Special Range	
	4	Atmospheric Pressure & Standard Background Gas	
	5	Biogas CH <sub>4</sub> and CO <sub>2</sub>	
	6	0-21% O <sub>2</sub> in N <sub>2</sub> and 14% CO <sub>2</sub> in N <sub>2</sub>	
	S	Special	
	<b>Safety Level</b>		
SIL	SIL2 By Design		
STN	Standard Industry Model		
<b>Special</b>			
0	No Special		
S	Special*		

\*Choose between RS232 and RS485 for the no display model or another option not listed above.

XMO2pro 2 1 4 0 0 6 1 SIL 0



**CORAME SAS**  
 MESURE-CONTROLE-AUTOMATISME  
 Tél: ROUEN 02 35 59 62 50 / CAEN 02 31 35 76 45  
 www.corame.fr info@corame.fr



panametrics.com

Join the conversation and follow us on LinkedIn  
[linkedin.com/company/panametricscompany](https://www.linkedin.com/company/panametricscompany)

Copyright 2025 by Panametrics LLC. All rights reserved.  
 PANA079DS\_R12 (09/2025)