



# oxy.IQ

## Panametrics Oxygen Transmitter

With a height of only 10.4 cm (4.1 in) and an integrated display, the oxy.IQ is a highly reliable, cost-effective two-wire, loop-powered transmitter with a linearized 4 to 20 mA output for use in the ppm to % level oxygen measurements. It measures oxygen in ten ppm ranges and six percentage ranges. All ranges are user-selectable. This compact transmitter uses proven sensor technology to accurately measure O<sub>2</sub> in a variety of gases, even in hazardous environments.

PANA024DS Rev. 13

## Proven sensor technology

The oxy.IQ's oxygen sensor is an advanced galvanic fuel cell that provides superior performance, accuracy, stability and long life. The cell's innovative design eliminates the potential for negative signal output, reduces sources of contamination. The cell is unaffected by other background gases or hydrocarbons and is compatible with acid gases (OX-2 and OX-4 cells). Recovery from air at low ppm levels takes just a few minutes. Because the cell is self-contained, minimal maintenance is required. There is no electrolyte to change or electrodes to clean.

## Intrinsically safe

When equipped with optional zener barriers or a galvanic isolator, the oxy.IQ can be mounted in a hazardous (classified) location.

## Control at the tip of a finger

The rugged oxy.IQ is controlled by a microprocessor that enables the user to select the range, trim outputs and perform calibration. Improved user interface includes user-selectable and programmable ranges, sensor diagnostics including a sensor lifetime feature and sensor raw signal, low reading/sensor failure signal and temperature compensation. Programming is easily done using the keypad and display. These keypad buttons allow complete functionality in hazardous areas when equipped with a zener barrier or a galvanic isolator per drawing 752-347.

## Installation flexibility

The compact oxy.IQ, with its built-in microprocessor, is designed to fit easily into any installation site. The oxy.IQ can be installed right at the sampling point, whereas other transmitters must be rack or panel mounted.

## Sample systems

In addition to standard features and options, Panametrics offers a full line of sample handling systems for a variety of applications. If needed, Panametrics can design and build a sample conditioning system to meet unique application requirements. Please contact Panametrics for details.

## Oxygen sensor interference gases

Gas	OX-1 and OX-5, ppm	OX-2, ppm.	OX-3, %		OX-4, %	
	Cont	Cont	Cont.	Int (1)	Cont.	Int (1)
H <sub>2</sub> S	<5 ppm	<10 ppm	0.0005%	0.01%	0.001%	0.1%
SO <sub>3</sub>	<10 ppm	<10 ppm	0.01%	0.1%	0.01%	20.1%
SO <sub>2</sub>	<10 ppm	(3)	0.01%	0.1%	(3)	(3)
HCl	<1000 ppm	(3)	0.1%	1.0%	(3)	(3)
HCN	<1000 ppm	(3)	0.1%	1.0%	(3)	(3)
CO <sub>2</sub>	<5000 ppm	(3)	0.1%	20%	(3)	(3)
NO <sub>2</sub>	(2)	(2)	(2)	(2)	(2)	(2)

Cont. = Continuous, Int. = Intermittent

(1) Recommended maximum exposure 30 minutes followed by flushing with ambient air for equal period

(2) Minimal effect on sensor performance, but produces signal interference of 1:2 ratio, ppm levels only. For example, 100 ppm NO<sub>2</sub> looks like 200 ppm O<sub>2</sub>

(3) Minimal effect on sensor performance

## Features

- Two-wire, loop-powered 4 to 20 mA transmitter
- Display with keypad
- Intrinsically safe option for Class 1 Div 1 and Div 2 locations, and ATEX/IECEX Zone 0
- Non Incendive for Div 2 locations
- Ex flameproof option
- Proven galvanic fuel cell O<sub>2</sub> sensor technology
- User selectable ranges for ppm and percent oxygen
- User-friendly and intuitive user interface with diagnostics
- Microprocessor-based, all-digital technology for reliable operation
- Low maintenance, economical and compact
- Sensor failure output error
- Sensor lifetime indication
- NAMUR error indication

## Applications

An oxygen transmitter for use in:

- Glove box purge and leak detection
- Natural gas
- Semiconductor wafer machines
- Coating process machines
- Membrane air separators
- Inert welding gases
- Pure gaseous hydrocarbon streams
- Process monitoring of gaseous monomers
- Heat treating and bright annealing

# Technical Specifications

## Intrinsically safe (IS) installation

Intrinsically safe installations require a zener barrier, one IS cable and one non-IS cable.

<b>Power requirements</b>	24 to 28 VDC at 50 mA
<b>Cable</b>	PN 704-1318: blue jacket, twisted pair with connector; 26 AWG; 2W or 10 m length
<b>Output</b>	Total load must equal 250 $\Omega$ $\pm$ 5% when using zener barrier

## General purpose and non-incendive (Div 2) installations

Standard option package or IS package, no Zener barrier or galvanic isolator is required.

## Flameproof installation

Standard option mounted in Flameproof enclosure for ATEX or IECEx locations.

<b>Power requirements</b>	24 to 28 VDC at 50 mA
<b>Cable</b>	PN 704-1317: black jacket, twisted pair with connector; 26 AWG; 2 or 10 m length

## All installations

<b>Process wetted materials</b>	SS process unit: 316 stainless steel, Viton® O-ring, gold plated sensor electrical contacts and glass (Chemraz O-Ring Option)
<b>Accuracy</b>	<ul style="list-style-type: none"> <li>• <math>\pm</math>1% of range at calibration point</li> <li>• <math>\pm</math>2% of range at the calibration point for the 0 to 10 ppmv range (OX-1 or OX-2 only)</li> </ul>
<b>Repeatability</b>	<ul style="list-style-type: none"> <li>• <math>\pm</math>1% of range</li> <li>• <math>\pm</math>2% of Range for the 0 to 10 ppmv range (OX-1, 2 only)</li> </ul>
<b>Resolution</b>	$\pm$ 0.1% of range
<b>Linearity</b>	<ul style="list-style-type: none"> <li>• <math>\pm</math>2% of range (OX-1, 2, 3, 5)</li> <li>• <math>\pm</math>5% of range (OX-4)</li> </ul>
<b>O<sub>2</sub> sensor operating temperature</b>	<ul style="list-style-type: none"> <li>• 32 to 113°F (0 to 45°C)</li> </ul>

### User-selectable measurement ranges

- PPM sensors:
  - 0 to 10 ppmv O<sub>2</sub> (OX-1 or OX-2 only)
  - 0 to 20 ppmv O<sub>2</sub> (OX-1 or OX-2 only)
  - 0 to 50 ppmv O<sub>2</sub> (OX-1 or OX-2 only)
  - 0 to 100 ppmv O<sub>2</sub>
  - 0 to 200 ppmv O<sub>2</sub>
  - 0 to 500 ppmv O<sub>2</sub>
  - 0 to 1000 ppmv O<sub>2</sub>
  - 0 to 2000 ppmv O<sub>2</sub>
  - 0 to 5000 ppmv O<sub>2</sub>
  - 0 to 10,000 ppmv O<sub>2</sub>
- Percent sensors:
  - 0% to 1% O<sub>2</sub>
  - 0% to 2% O<sub>2</sub>
  - 0% to 5% O<sub>2</sub>
  - 0% to 10% O<sub>2</sub>
  - 0% to 25% O<sub>2</sub>
  - 0% to 50% O<sub>2</sub>

### Sample pressure

- Vented to atmosphere during operation and calibration
- 10 psig (0.69 barg) maximum sample operating pressure (except when using ambient air adapter for the sample manifold)
- 200 psig (13.78 barg) sample manifold burst pressure (for all bases except ISO-KF-40 flange adapter)
- ISO-KF-40 is designed for a vacuum flange, where a positive sample pressure is not desired.

### Atmospheric pressure effect

$\pm$ 0.13% of reading per mmHg (directly proportional to absolute pressure). During calibration, pressure and flow must be kept constant.

### Process connection

1/8 in. NPT inlet and outlet oxy.IQ Specifications

### Dimensions

4.10 x 2.75 x 2.05 in.  
(104.1 x 69.9 x 52.1 mm)

### Weight

1.35 lb (612 grams)

### Sample flow rate

1.0 SCFH (500 cc/min) recommended for process units

### Electrical classification/certification

Intrinsically safe

#### USA/Canada:

- IS for Class I, Div 1, Groups ABCD, T4

#### ATEX and IECEx:

- Ex ia IIC Ga T4 Tamb -20 to 60°C

#### IS package, non-incendive without use of Zener barrier or galvanic isolator:

- USA/Canada: Class I, Div 2, Groups A, B, C, D; T4

#### Flame proof package:

- ATEX/IECEx Ex d IIC T4 IP66

**European compliance** Complies with EMC directive 2014/30/EU

## Dimensions

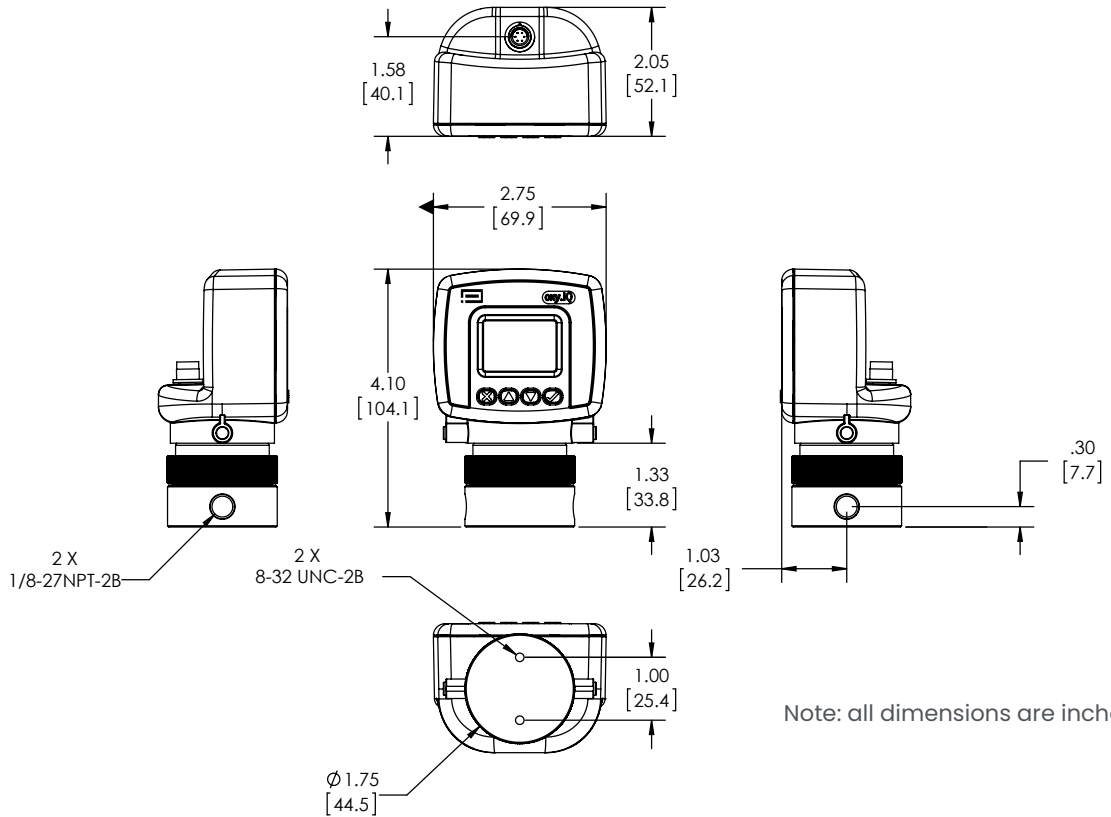

Note: all dimensions are inches [mm]

### FLAMEPROOF VERSION (ATEX/IECEX ONLY)

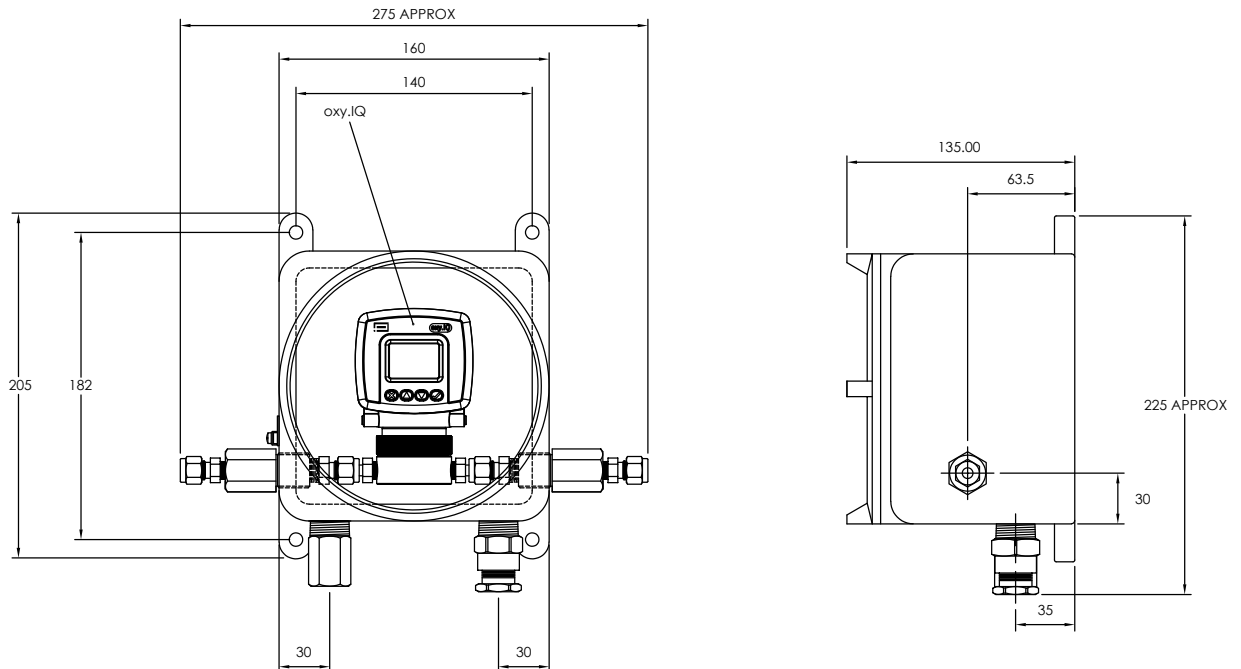

Note: Flameproof version dimensions are shown as mm only

# Installation options

## Hazardous Location

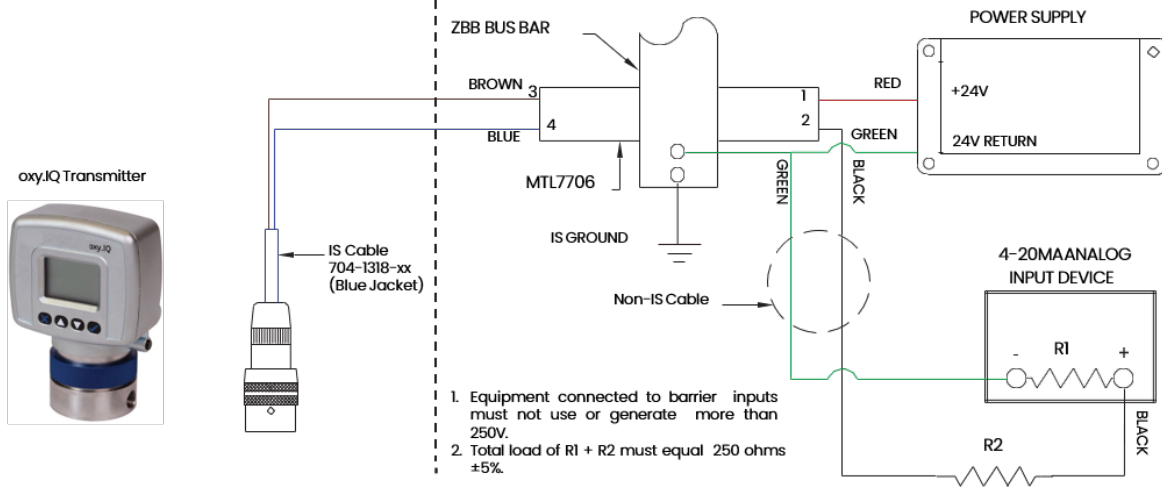

## Hazardous Location | Non-Hazardous Location

### Class 1 Div 2 Enclosure

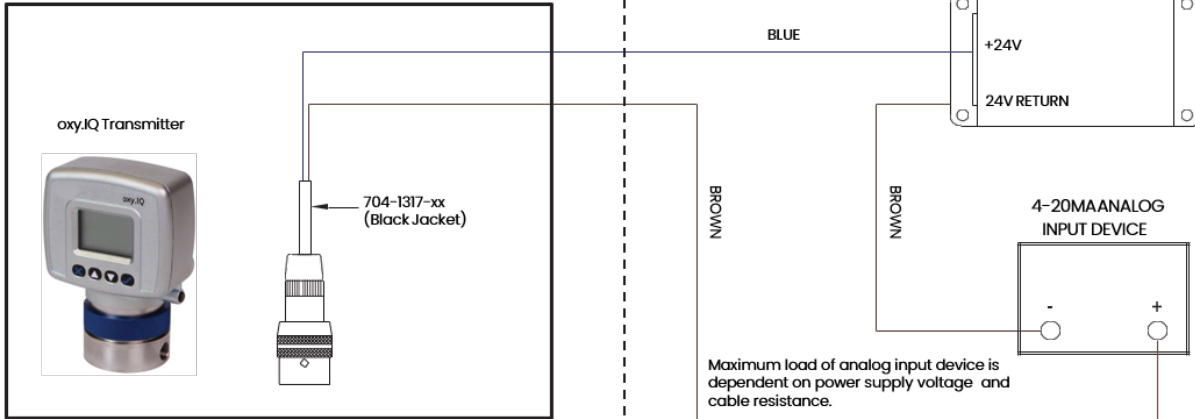

1. For Class 1 Div 2 installation, the oxy.IQ shall be installed in an appropriately rated final enclosure accepting a Division 2 wiring method per NEC/CEC.

### Non-Hazardous Location

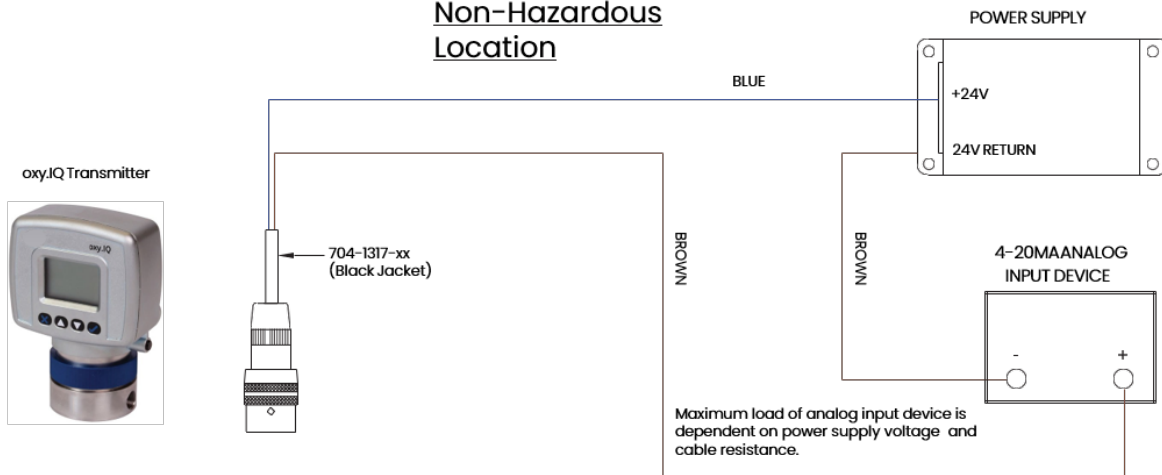

## Installation options

Record selected option in blank spaces indicated at bottom of form.  
 OXY.IQ-BCD-E Option Code

### A - Model only

oxy.IQ Oxygen Transmitter; 4 to 20 mA output

### B - Sensor

- 0 No sensor
- 1 Standard ppm, 0 to 10, 20, 50, 100, 200, 500, 1000 ppm
- 2 Acid ppm, 0 to 10, 20, 50, 100, 200, 500, 1000 ppm
- 3 Standard percent sensor
- 4 Acid percent sensor
- 5 Standard ppm, 0 to 100, 200, 500 and 1000 ppm

### C - Package

- 1 Standard
- 3 Intrinsically safe for ATEX/IECEX and US/CAN Class 1 Div1 or Non-incendive for US/CAN Class 1 Div 2
- 4 EX&IP66 ATEX/IECEX 6mm fittings in aluminium enclosure
- 5 EX&IP66 ATEX/IECEX 1/4" fittings in aluminium enclosure
- 6 EX&IP66 ATEX/IECEX 6mm fittings in 316SS enclosure
- 7 EX&IP66 ATEX/IECEX 316SS 1/4" fittings in 316SS enclosure

### D - Cable length

- 0 No cable
- 1 2 meter cable
- 2 10 meter cable
- 3 Demo cable

### E - Zener barrier

- 0 None
- 1 Zener barrier
- 2 Galvanic isolator

### F-Base adapter

- 0 Standard
- 1 O2X1 Adapter
- 2 TD Adapter
- 3 ISO KF/NW40 Adapter
- 4 Ambient Air Adapter

### S- Special

- 0 No special selected
- 1 CHEMRAZ o-ring
- 2 Special consult factory

Note : For Option C=3 intrinsic safety, either zener barrier or galvanic isolator must be selected. For Class 1 Div 2, no barriers needed. Please refer to dwg 752-347 installation guidelines.

**A**      **B**      **C**      **D**      **E**      **F**      **S**      [Use this number to order product]



Join the conversation and follow us on LinkedIn  
[linkedin.com/company/panametricscompany](https://www.linkedin.com/company/panametricscompany)

Copyright 2025 by Panametrics LLC. All rights reserved.

PANA024DS\_R13 (07/2025)

 **Panametrics**

[panametrics.com](https://panametrics.com)