



HygroPro XP

Aluminum Oxide Moisture Transmitter

This explosionproof aluminum oxide moisture transmitter measures moisture concentration in gases and non-aqueous liquids from trace to ambient levels. It is suitable for a wide range of applications including:

- Petrochemical
- Refinery
- Natural gas
- Hydrogen
- Industrial gas
- Power generation

The HygroPro XP moisture transmitter is a compact, 4–20 mA transmitter designed to meet the needs of the most demanding hazardous area applications. It features an integrated backlit display with a six-button programmable keypad, housed in an IP66/Type 4X rated explosion proof enclosure. The integrated display and keypad allow easy navigation of the software for configuration of the probe measurement, analog and digital (HART) output, and other user functions and diagnostics. The HygroPro XP has built-in multi-drop networking capability via the digital HART interface that allows multiple units to be connected on a single network.

Using an industry-proven state-of-the-art aluminum oxide moisture sensor, the HygroPro XP features a built-in thermistor and optional pressure transducer to provide real-time measurement of the sample dew/frost point, temperature and pressure. This allows for the calculation and display of other moisture content parameters such as ppmv in gases, ppmw in liquids, pounds per million standard cubic feet in natural gas and more.

The glass-to-metal seal in the probe measurement is certified to meet ANSL/UL 122701 single seal standards ensuring reliable isolation of the probe electronics from the process.

The HygroPro XP consists of a display head and a replaceable transducer element (RTE), which contains the aluminum oxide moisture sensor, thermistor and optional pressure transducer with associated electronics. The calibration data for the moisture and pressure sensors are stored on a non-volatile EEPROM in the RTE, the user does not need to enter any calibration data manually when changing an RTE.

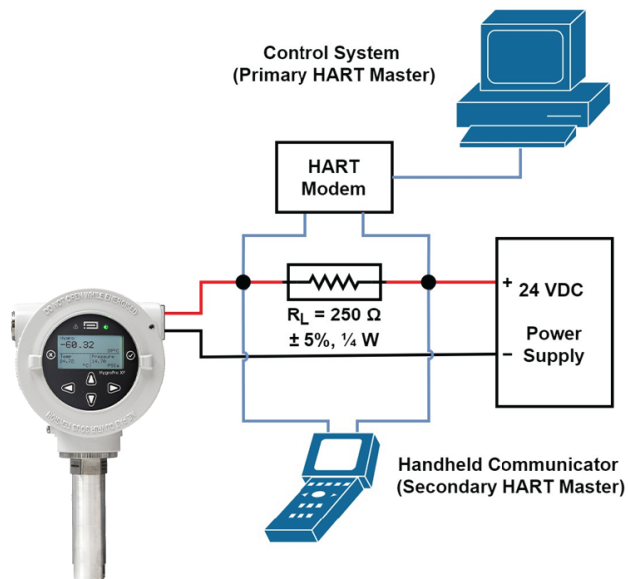

Typical hazardous area installation showing connection to an Analog output device/HART master.

Advanced moisture sensor technology

The HygroPro XP combines a technologically advanced aluminum oxide moisture sensor with onboard temperature compensation, state-of-the-art hygrometry software, and robust read-out electronics for unequalled overall performance. The probe is maintained dry during shipment using high-capacity desiccant packs inside a metal shipping cap, which if unscrewed just prior to installation on the process, enables fast dry down.

Calibration traceable to international standards

Superior sensitivity, speed of response, calibration stability, and wide dynamic range have made Panametrics aluminum oxide moisture probes the standard of performance and value in industrial moisture measurement. They are suitable for process and industrial moisture measurement applications in a wide variety of gases and hydrocarbon liquids over a wide range of process conditions. Calibration traceability is available to the NIST or the NPL with the option of an ISO 17025 accredited calibration.



Features

- Explosionproof
- Ambient to ppb-level moisture measurement using next-generation aluminum oxide moisture sensor
- Built-in temperature sensor for temperature compensation
- Optional pressure sensor
- Calibrations traceable to National Institute of Standards and Technology (NIST) or National Physical Laboratory (NPL) with the option of fully accredited calibration to ISO 17025
- Complete programming capability via User Interface that consists of integrated display and 6-button keypad
- Analog and digital outputs
- HART communication over the 4 – 20 mA analog output
- Electropolished 316/316L enclosure option
- Real-time clock for automatic calibration reminder

HygroPro XP

Specifications

Calibration ranges (dew/frost point)	Standard: 50 to -112°F (+10 to -80°C) with data from +68 to -166°F (+20 to -110°C)
Operating temperature	-4°F to 140°F (-20°C to 60°C)
Storage temperature	-22°F to 158°F (-30°C to 70°C)
Accuracy	<ul style="list-style-type: none"> ±3.6°F (±2°C) above -148°F (-100°C) ±5.4°F (±3°C) below -148°F (-100°C)
Repeatability	<ul style="list-style-type: none"> ±0.4°F (±0.2°C) above -148°F (-100°C) ±0.9°F (±0.5°C) below -148°F (-100°C)

Mechanical

Sample connection	<ul style="list-style-type: none"> 3/4-16 in. (19 mm) straight male thread with O-ring G 1/2 with optional adapter
Operating pressure	5 µm Hg to 5000 psig (345 bar)
Enclosure	Type 4X, IP 66
Dimensions	<p>H x W x D:</p> <ul style="list-style-type: none"> 8.63 x 4.80 x 3.51 in. (219 x 122 x 89mm) <p>Weight:</p> <ul style="list-style-type: none"> Aluminium: 5.5lbs (2.5kg) Stainless Steel: 11lbs (5kg)
European compliance	Complies with EMC directive 2014/30/EU
Hazardous area certification	<p>North America:</p> <ul style="list-style-type: none"> CI I,II,III Div 1/Div2, Gp ABCDEFG, T6 CI I, Zn 1, AEx/Ex db/ia IIC T6 Gb/Ga CI II, Zn 21 AEx/Ex tb/ia IIIC T85°C Db/Ga CI I, Zn 2, AEx/Ex dc/ia IIC T6 Gc/Ga CI II, Zn 22 AEx/Ex tc/ia IIIC T85°C Dc/Da -20°C < Ta < +60°C <p>ATEX/IECEX:</p> <ul style="list-style-type: none"> Ex db/ia IIC T6 Gb/Ga Ex tb/ia IIIC T85°C Db/Ga 20°C < Ta < +60°C

Electrical

Power	<ul style="list-style-type: none"> Voltage: 12 to 28 VDC (loop-powered, customer supplied) Output: 4 to 20 mA analog & HART digital Output Resolution: 0.01 mA/12 bits <p>Note: Class 2 rated power supplies (with functional GND) are recommended.</p>
Display	<ul style="list-style-type: none"> 128 x 64 LED backlit LCD Display from one to three parameters and diagnostics

Moisture sensor

Sensor type	Thin-film aluminum oxide moisture sensor
Calibration	Each sensor is individually computer-calibrated against known moisture concentrations, traceable to national standards
Calibration interval	Panametrics recommends moisture sensor recalibration every six to twelve months depending on application

Temperature sensor

Sensor type	NTC thermistor
Operating range	-22°F to 158°F (-30°C to 70°C)
Accuracy	±0.9°F (±0.5°C) overall

Pressure sensor

Sensor type	Solid state/piezoresistive
Available ranges	<ul style="list-style-type: none"> 30 to 300 psig (3 to 21 bar) 50 to 500 psig (4 to 35 bar) 100 to 1000 psig (7 to 69 bar) 300 to 3000 psig (21 to 207 bar) 500 to 5000 psig (35 to 345 bar)
Accuracy	±1% of full scale (FS)
Pressure rating	Three times the span of the specified range to a maximum of 7500 psig (518 bar)

HygroPro XP dimensions

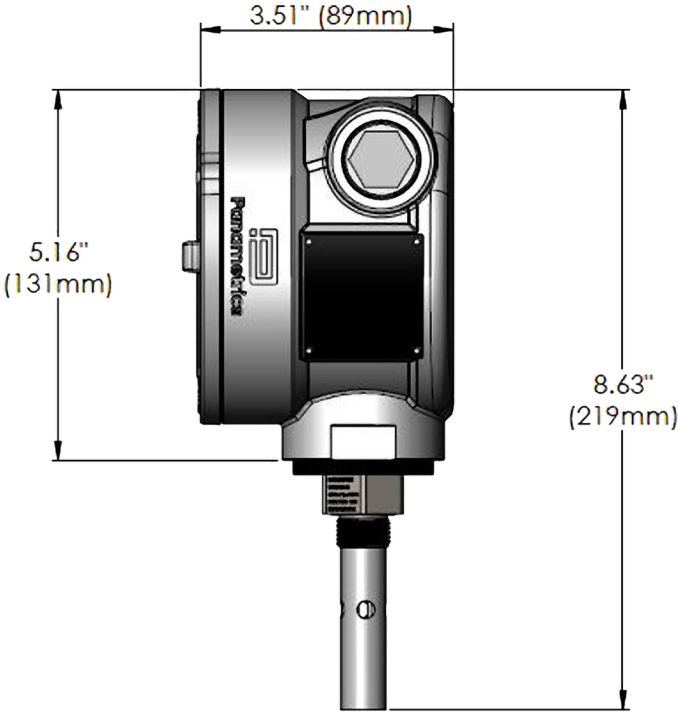
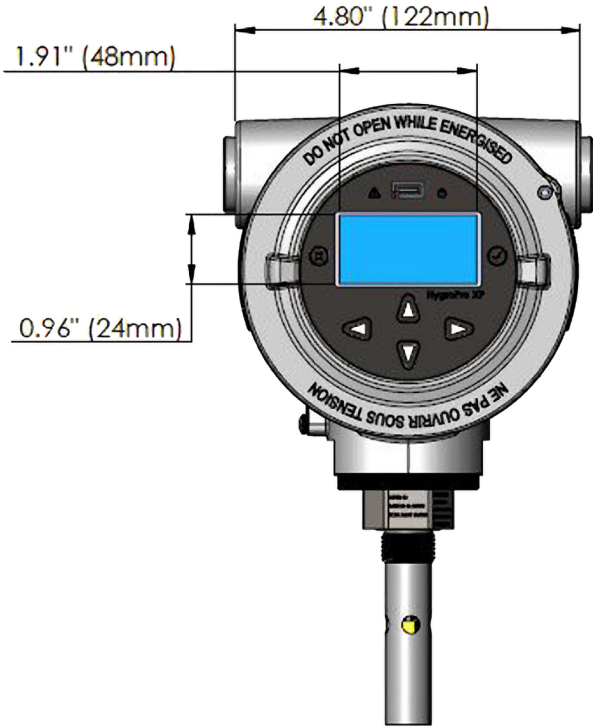

Configuration options

Record selected option in blank spaces indicated at bottom of form.

HYGROPRO XP-B-C-D-E-F-G-H-I-J Option Code

A - Model only

HYGROPRO XP: HygroPro XP absolute moisture transmitter

B - Transmitter Head/Display

- 1 Aluminum
- 2 316 Stainless Steel

C - Pressure Transducer on Probe

- 0 None
- 1 30 to 300 psig pressure transducer
- 2 50 to 500 psig pressure transducer
- 3 100 to 1000 psig pressure transducer
- 4 300 to 3000 psig pressure transducer
- 5 500 to 5000 psig pressure transducer

D - Laboratory Services

- 0 None
- 1 Cleaning for oxygen service

E - Calibration Certification

- 0 None
- 1 NIST Certificate
- 3 ISO-17025 Calibration
- 4 NPL Certificate

F - O-ring Options

- 0 Standard Viton O-ring
- 1 Teflon O-ring
- 2 CPA-70 O-ring
- 3 Kalrez O-ring

G - Material Certification

- 0 None
- 1 NACE/EN 10204.3.1 Compliant

H - Calibration

- 0 Standard Calibration, -80 to +10 °C dew/frost point. Data from -110 to +20 °C
- 1 Low-End Calibration, -100 to -50 °C dew/frost point. Data from -110 to -50 °C

I - Hazardous Area Certification

- 1 US/Canada Class I Div 1, Zone 1/21
- 2 US/Canada Class I Div 2, Zone 2/22
- 3 ATEX/IECEx/UKEX Zone 1

J - Special

- 0 None
- 1 Special, Consult Factory

A - B - C - D - E - F - G - H - I - J



CORAME SAS
 MESURE-CONTROLE-AUTOMATISME
 Tél: ROUEN 02 35 59 62 50 / CAEN 02 31 35 76 45
 www.corame.fr info@corame.fr

Join the conversation and follow us on LinkedIn
[linkedin.com/company/panametricscompany](https://www.linkedin.com/company/panametricscompany)

Copyright 2025 by Panametrics LLC. All rights reserved.
 PANA075DS_R8 (04/2025)



[panametrics.com](https://www.panametrics.com)